

Candidate Name \_\_\_\_\_

Centre Number	Candidate Number

**CAMBRIDGE INTERNATIONAL EXAMINATIONS**  
**Joint Examination for the School Certificate**  
**and General Certificate of Education Ordinary Level**

**BIOLOGY**

**5090/3**

PAPER 3 Practical Test

**OCTOBER/NOVEMBER SESSION 2002**

1 hour 15 minutes

Candidates answer on the question paper.  
Additional materials:  
As listed in Instructions to Supervisors

**TIME** 1 hour 15 minutes

**INSTRUCTIONS TO CANDIDATES**

Write your name, Centre number and candidate number in the spaces at the top of this page.

Answer **both** questions.

Write your answers in the spaces provided on the question paper.

Use a sharp pencil for your drawings. Coloured pencils or crayons should **not** be used.

**INFORMATION FOR CANDIDATES**

The intended number of marks is given in brackets [ ] at the end of each question or part question.

FOR EXAMINER'S USE	
1	
2	
TOTAL	

---

**This question paper consists of 6 printed pages, a Supervisor's Report and 1 blank page.**



**Instructions to candidates**

Read the whole of the question paper carefully before you begin.

Set up the experiment for Question 1 and then go on to Question 2 while you are waiting. Leave at least 15 minutes to complete Question 1 before the end of the examination.

- 1 You are required to investigate the concentration of the cell sap in potato tissue. You are provided with one or more slices of potato tissue.
- (a)
- Remove the potato tissue from the solution and blot it gently to remove surface liquid.
  - Cut 4 strips of potato, exactly 70 mm long by approximately 10 mm wide.
  - Put a strip into each of the salt solutions, **A**, **B**, **C** and **D**, so that the strips are completely covered.
  - **Leave them for at least 25 minutes and, during this time, start Question 2.**
  - After 25 minutes, remove the strip from solution **A**, blot it gently, then measure the length of the strip to the nearest 0.5 mm.
- (i) Record the measurement in Table 1.1.
- Repeat this procedure for the strips from solutions **B**, **C** and **D**.
- (ii) Complete Table 1.1.

**Table 1.1**

solution	salt concentration / mol per dm <sup>3</sup>	initial length / mm	final length / mm	change in length / mm
<b>A</b>	0.2			
<b>B</b>	0.4			
<b>C</b>	0.6			
<b>D</b>	0.8			

[5]

(b) Draw a graph of change in length against salt concentration, using the axes provided.

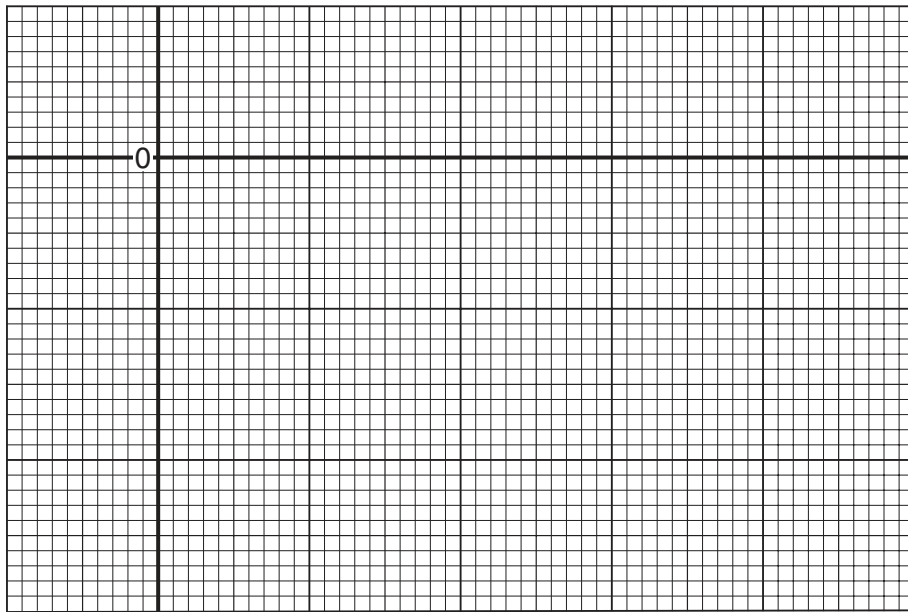

[6]

(c) From your graph, determine the value at which the salt solution and the potato tissue are in equilibrium.

.....[1]

(d) Describe and explain what would happen to the cells if the potato strip was taken from solution D and put in distilled water for about one hour.

.....

.....

.....

.....

.....

.....

.....

.....[4]

(e) Suggest three ways in which this investigation could be made more reliable.

1. ....
  2. ....
  3. ....
- .....[3]

[Total : 19]

[Turn over

- 2 Specimens **W31** and **W32** are slices of two fruits; they show some common features and some differences.
- (a) (i) Make a large, labelled drawing of each specimen in the spaces provided. Detailed structure should be shown for a sector, approximately one third to one quarter of each specimen.

**W31**

**W32**

[8]

(ii) List three visible features that are the same in both specimens.

1. ....
2. ....
3. ....[3]

(iii) In Table 2.1, list **five** pairs of contrasting features that are visible in the two specimens.

**Table 2.1**

	<b>W31</b>	<b>W32</b>
1		
2		
3		
4		
5		

[5]

(b) Estimate, as accurately as you can, the total number of seeds that were present in the fruit from which **W31** was taken, proceeding as follows.

- Cut **W31** into equal quarters.
- Place one of these on the tile and, using the scalpel blade, squeeze out all of its seeds.

(i) Count them and record the number.

number of seeds = .....

(ii) Repeat for another of the quarters.

number of seeds = .....

(iii) Calculate the number of seeds in the whole slice. Show your working.

number of seeds in whole slice = .....

Fig. 2.1 shows, in longitudinal view, the extent of the seed-containing cavity and the position from which **W31** was taken.

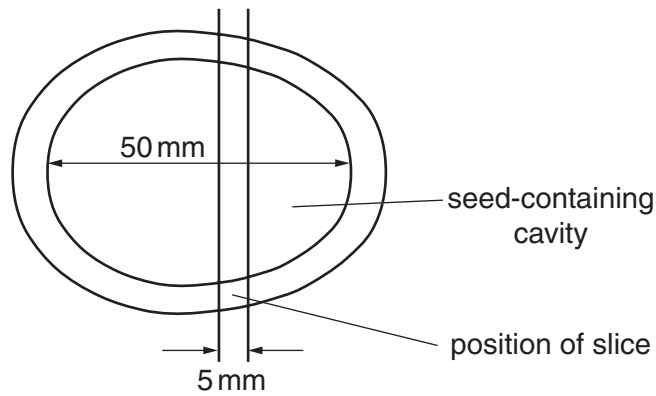

**Fig. 2.1** (Not to scale)

- (iv) Use this to calculate the number of slices that could be obtained from one fruit.

number of slices = .....

- (v) Calculate the total number of seeds in the whole fruit, making and explaining any allowance you may think necessary.

total number of seeds in whole fruit = .....

[5]

[Total : 21]



**SUPERVISOR'S REPORT**

*\*The Supervisor or Teacher responsible for the subject is asked to answer the following questions.*

- 1 Was any difficulty experienced in providing the necessary materials? If so, give brief details.
  
- 2 Did the candidate experience any difficulty during the course of the examination? If so, give brief details. Reference should be made to
  - (a) difficulties arising from faulty specimens;
  - (b) accidents to apparatus or materials;
  - (c) any information that is likely to assist the Examiner, especially if this cannot be discovered from the scripts.

- 3 Please count the number of seeds in a quarter from a central slice and from a marginal slice of **W31**.

Central slice = .....

Marginal slice = .....

*Declaration to be signed by the Principal, and completed on the top script from the Centre*

The preparation of the practical examination has been carried out so as to fully maintain the security of the examination.

Signed .....

Name (in block capitals) .....

**\*Information that applies to all candidates need only be given once.**

N.B. If scripts are required by CIE to be despatched in more than one envelope, it is essential that a copy of the relevant Supervisor's Results (when requested), the Supervisor's Report and the appropriate seating plan are sent inside each envelope.